



Confederation of Indian Industry



CII EXIM BANK AWARD FOR BUSINESS EXCELLENCE

2 0 2 4



The Confederation of Indian Industry (CII) works to create and sustain an environment conducive to the development of India, partnering Industry, Government and civil society, through advisory and consultative processes.

CII is a non-government, not-for-profit, industry-led and industry-managed organization, with around 9,000 members from the private as well as public sectors, including SMEs and MNCs, and an indirect membership of over 300,000 enterprises from 286 national and regional sectoral industry bodies.

For more than 125 years, CII has been engaged in shaping India's development journey and works proactively on transforming Indian Industry's engagement in national development. CII charts change by working closely with Government on policy issues, interfacing with thought leaders, and enhancing efficiency, competitiveness and business opportunities for industry through a range of specialized services and strategic global linkages. It also provides a platform for consensus-building and networking on key issues.

Extending its agenda beyond business, CII assists industry to identify and execute corporate citizenship programmes. Partnerships with civil society organizations carry forward corporate initiatives for integrated and inclusive development across diverse domains including affirmative action, livelihoods, diversity management, skill development, empowerment of women, and sustainable development, to name a few.

As India strategizes for the next 25 years to India@100, Indian industry must scale the competitiveness ladder to drive growth. It must also internalize the tenets of sustainability and climate action and accelerate its globalisation journey for leadership in a changing world. The role played by Indian industry will be central to the country's progress and success as a nation. CII, with the Theme for 2023-24 as 'Towards a Competitive and Sustainable India@100: Growth, Inclusiveness, Globalisation, Building Trust' has prioritized 6 action themes that will catalyze the journey of the country towards the vision of India@100.

With 65 offices, including 10 Centres of Excellence, in India, and 8 overseas offices in Australia, Egypt, Germany, Indonesia, Singapore, UAE, UK, and USA, as well as institutional partnerships with 350 counterpart organizations in 133 countries, CII serves as a reference point for Indian industry and the international business community.

ABOUT THE TROPHY

Coveted.

The trophy was designed for three specific facets of all that Excellence, in an Organisation, stands for.

The three columns represent the Organisation's people, processes and performance.

The orb or globe at the apex represents the synergy of an Organisation wherein all the elements are harmoniously integrated at its pinnacle.

The columns are polished, reflecting continuous effort the best mantra for excellence and competitiveness, resulting in an agile Organisation. The gold sheen is representative of nobility.

The polished granite base upon which everything rests symbolises the unflinching commitment of the leadership.

The trophy was specifically designed by National Institute of Design, Ahmedabad.

CII EXIM BANK AWARD FOR BUSINESS EXCELLENCE

Aspired for.



02

CII EXIM BANK
AWARD FOR
BUSINESS
EXCELLENCE
2 0 2 4

**OUTSTANDING ORGANISATIONS
ACHIEVE AND SUSTAIN LEVELS
OF PERFORMANCE THAT MEET OR EXCEED
THE EXPECTATIONS OF ALL THEIR STAKEHOLDERS**



CONTENTS

Global Guardians of Premier Excellence Models - GEM Council	04
CII EXIM Bank Award for Business Excellence – FAQ	05
Eligibility Criteria	06
How to Apply for the Award	07
How the Organisation is Assessed	12
Award Assessment Process	13
Recognitions	16
Application Form 2024	23
Acknowledgment	25
Winners so far	26
Business Excellence Maturity Assessment Programme	37

GLOBAL
EXCELLENCE
COUNCIL**Global Excellence Council**

The Global Excellence Council consists of Organisations that are recognised globally as the guardians of premier Excellence Models and Award processes in their specific geographical region/area or trading block. These not-for-profit Organisations provide mutual learning and sharing of good practices and initiatives, and maintain direct access to the private and public sectors. They place their Excellence mission above short-term commercial exploitation.

GEM Council members support and promote the interests and activities of GEM, participate in cross-national working groups and acknowledge the mutual benefits of sharing and learning activities. The ambition of the GEM Council is to ultimately secure membership from each significant geographical region/trading block across the globe.

GEM Council Mission Statement

Through a formalised approach for sharing knowledge, experience and information, the members of GEM Council, as guardians of Premier Excellence Models and Award processes globally, enhance the value for their customers and other stakeholders by:

- Maintaining a leading edge position on Excellence Models
- Sensing business trends and external factors which impact the Excellence Models
- Creating a global fraternity in the field of Excellence
- Exploring opportunities for new products/activities
- Coordinating and sharing specific Excellence Award activities
- Agreeing consistent public communications on Organisational Excellence

The first meeting of GEM Council took place in October 2000 with GEM founding members AQC (Australia), Baldrige Performance Excellence Program (USA), EFQM (Europe), JQA (Japan), SAEF (S. Africa; Defunct in 2005) and SPRING (Singapore). The GEM Council meets annually at the premises of one of its members.

Current members of the GEM Council

- Australian Organisational Excellence Foundation AOE (Australia)
- Baldrige Performance Excellence Program (USA)
- CAQ (China)
- **CII-IQ (India)**
- DGEP (United Arab Emirates)
- EFQM (Europe)
- FNQ (Brazil)
- FUNDIBEQ (Iberian Peninsula and Latin America)
- IFCT (Mexico)
- JQA (Japan)
- Malaysia Productivity Corporation (Malaysia)

CII AWARD FOR BUSINESS EXCELLENCE

Frequently Asked Questions

What is the CII EXIM Bank Award for Business Excellence?

CII EXIM Bank Award for Business Excellence, instituted by CII in the year 1994, is the most prestigious Award in India for Excellence that an Indian company can aspire for.

The Award is based on a comprehensive model focusing on the Organisation's performance and transformation under seven different criteria, which are further divided into twenty five parts. It is not given for specific products or services. To be an Award winner, a company must demonstrate excellence in results with respect to its various stakeholders (customers, employees, society and share holders) through excellence in processes and people.

Why was the Award established?

The Award was established to promote the awareness of Excellence as an increasingly important element in competitiveness. Not only does it recognise excellent businesses, but also increases the understanding of the elements critical for Excellence. To accomplish this, the Award promotes information sharing of successful performance strategies and the benefits derived from pursuing these strategies.

How do Organisations apply?

The first step is to submit a brief form to establish that the Organisation is eligible to apply for the Award. Once eligibility has been determined, the second step consists of preparing and completing an Application Form and Position Report. The Position Report should summarise the Organisation's Practices and Results in response to the Award Criteria for Excellence.

What does an Organisation receive in return?

- Recognition at a National CII Platform
- Outside in perspective from the Assessments identifying blind spots
- New Focus areas to facilitate growth
- Fit for future- Sustainability Meter
- Effectiveness & Efficiency improvements across processes
- Embedding a culture of stakeholder focus linked to Business results

What is expected of Award Recipients?

Award & Role Model Recipients are required to share information on their successful performance and quality strategies with other Indian Organisations. Recipients are not required to share proprietary information, even if such information was part of the Award Application. The principal mechanism for sharing information is the Excellence Summit, an annual flagship event and a series of 'Winners' Conferences' held in the major cities of the country.

In addition, the Award Recipients are required to make 'Soft Copy' of the Position Report available to CII before 31 December of the same year (suitably editing proprietary information, if any) for sharing among the interested Organisations.

06

CII EXIM BANK
AWARD FOR
BUSINESS
EXCELLENCE
2 0 2 4

ELIGIBILITY CRITERIA

All Organisations operating in India and Overseas units of Indian Organisations are eligible to apply for the Award. The Applicant must have been actively in business at least for the past three years.

The following types of Organisations are eligible to participate:

- Large Business Organisations
- Operating Units of Large Business Organisations
- Small and Medium Business Organisations*

Large Business Organisations

Whole Organisations or part of Organisations run as Business units satisfying all the following characteristics:

Annual Sales/Revenue is more than Rupees One hundred crore (applicable as per the financial year 2022-2023)

Run as an Independent Profit Centre with a full set of accounts (published balance sheet)

The unit has a broad range of support functions/policies, which it has autonomy over HR, Finance, IT etc

In addition, the unit may demonstrate its independence by using a name/brand unique to that of the parent Organisation

Operating Units of Large Business Organisations

Operating units are part of a parent organisation, with the following characteristics:

Annual sales/revenue of a parent organisation, should be more than Rupees one hundred crore

Annual sales/revenue of the operating unit applying should be a minimum of Rupees fifty crore

The unit is dependent on the parent organisation in some areas like HR, Finance, IT etc.

Small and Medium Business Organisations*

Whole Organisations with Annual Sales / Revenue less than Rupees One Hundred Crore

Notes

1. Any Organisations operating in India and its Overseas Units may apply for the Award.
2. The Organisation should be in existence for a minimum of three years.
3. Number of Operating Units/SBUs of a Large Business Organisation eligible for participation in the Award Programme is a maximum of 10 (Ten).
4. Refer pages 13 - 15 of the Award Application Brochure for the Award Assessment Process and Levels of Recognition.
5. It is expected that a minimum of 3 to 5 Senior Management Personnel of the Organisation should have undergone the 'Three day Workshop on Assessment for Business Excellence for Large Business Organisations / Operating Units', prior to submission of the Position Report.
6. *For all information relevant to Small & Medium Business Organisations, please refer 'Award & Model Brochure for Small & Medium Businesses.
7. Annual Sales / Revenue is considered for the recently concluded full financial year with respect to the last date for Receipt of Application.
8. Regarding the eligibility criteria and the award process, the decision of CII Award Secretariat will be final.

Time Table for the Year 2024

30 April 2024

Final Date for Receipt of Application Form by CII Award Secretariat.

15 July 2024

Final Date for Receipt of the Position Report by CII Award Secretariat.

15 July - 15 October 2024

Onsite Assessment, where applicable.

The Announcement of Results will be made at the Excellence Summit during November 2024.
(Three Senior Officials from all Applicant Organisations are eligible to attend the National Excellence Summit, as Special Invitees).

HOW TO APPLY FOR THE AWARD

1. Time Table for the year 2024

30 April 2024

Final Date for Receipt of Application Form by
CII Award Secretariate.

15 July 2024

Final Date for Receipt of the Position Report by
CII Award Secretariate.

15 July - 15 October 2024

Onsite Assessment, where applicable.

2. Application Form

Check the eligibility and appropriate category before filling the Application Form (Refer page 6). The Application Form is given on pages 23 and 24 of this Brochure. The Position Report is to be formatted in line with the criteria of the EFQM Model. The Application Form should be completed and forwarded to CII to review by the date shown in the Time Table (Note: Also a second copy of the Application Form is required as a part of the Position Report - see below).

3. Position Report

3.1 Position Report should be:

- In type-script
- In English
- Text in 11 point Arial Font and figures in 9 point Arial Narrow.
- A4 Size Paper, Two side printing is preferred, provided the contents in both pages are legible and has no shadow effect of the other side printing
- Numbered pages loosely-bound (spiral bound) (for ease of processing)
- The Position Report should include the following:
 - Organisation Profile , not exceeding 5 pages(Refer section 3d)
 - Sub criteria details from 1.1 to 5.5 along with results of criteria 6 & 7
 - Result Overview - 1 Page
 - Key external factors - 1 Page
 - Table of Contents (section 3.3c)
 - Glossary of Terms (section 3.3f)
 - Note: Any additional details in excess of the prescribed pages, indicated above, will not be taken into account.
 - Please leave the maximum margin on each page as per the details
- Copy of the Application form

- Copy of the organization structure, if not part of the main document

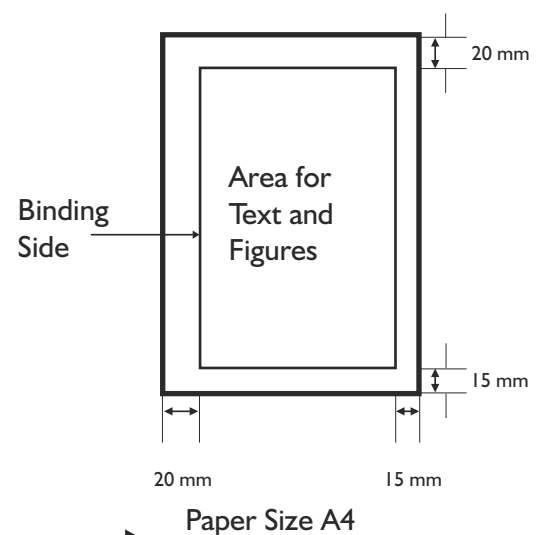

HOW TO APPLY FOR THE AWARD

3.2 Nine (9) identical copies of the Position Report

3.3 The Position Report should be divided into the following sections:

a. Title Page

The name of the Organisation or Business entity making the Application, its address and the Date of the Application.

b. Application Form

Please include a completed copy of the Application Form and have the Highest-Ranking Official of the Organisation sign it. The signature indicates that all the information contained in the Application is correct, that fee will be paid, and that all requirements of the submission and the eligibility rules have been met.

The Application Form is to be found on pages 23 and 24 of this Brochure.

c. Table of Contents

Please give the Table of Contents with page number.

d. Organisational Profile

The Organisational Profile is a summary of upto four pages of information about the Applicant and its Business, and should address the following key areas:

Op I. Organisational Environment

i. Introduction / Overview

Provide a brief history about the Organisation including Parent Organisation, as applicable (in not more than 500 words)

ii. Legal Status of the Organisation and Investor Profile

Briefly provide information about the Legal status & Investor profile

Example: Private Ltd., Public Ltd., Proprietary, NGO etc

Number of Investors, Major Investors, % Shareholding etc., as applicable

iii. Mission, Vision and Values

What are the stated Purpose, Vision, Mission, and Values?

iv. Product / Service Offerings

a) What are the main product/service offerings of the Organisation?

b) What is the delivery/distribution mechanism you use to deliver your products/services to the customer?

v. People/Employee/ Workforce Profile

a) Provide details about People*/ Employee/Workforce profile, groups and segments (*For People, refer definition given under Glossary of EFQM Excellence Model)

b) What are their educational levels? Educational requirements for different employee groups/segments

c) What are the Organisation's workforce and job diversity focus/details?

d) What are your organised bargaining units (Union Representation), use of contract employees?

e) What are your Organizations Special Health and Safety Requirements?

vi. Assets

What are your major

a) Technologies

b) Equipment

c) Infrastructure/ Facilities

d) Any other Assets

vii. Regulatory Requirements

a) What is(are) the regulatory environment under which the Organisation operates?

b) What are the key applicable occupational health and safety regulations?

c) What are the applicable accreditation, certification, or registration requirements?

d) What are the Industry standards, environmental, financial and product regulations?

HOW TO APPLY FOR THE AWARD

AWARD APPLICATION BROCHURE

Op2. Organisational Relationships

a) Organisational Structure

What is the Organisational Structure and Governance System? What are the reporting relationships among Board of Directors, Senior Leaders, and the Parent Organisation, as appropriate?

b) Customers and Stakeholders

What are your Key Customer and Market Segments, as appropriate?

What are their Key requirements and expectations for the products and services?

What are the differences in these requirements and expectations between Customers, Stakeholder groups and Market Segments?

c) Suppliers and Partners

What role do Suppliers, Service Providers, Partners and Distributors play in value creation process & enhancing Competitiveness? What are the most important types of Suppliers, Service Providers, Partners and Distributors?

What are the Key Suppliers and Customer Partnering relationship and Communication mechanisms (two-way)?

What role, if any, do these suppliers/partners play in contributing and implementing Innovations in your Organisation?

What are your key Supply-chain requirements?

Op3. Competitive Environment

a) Competitive Position

What is your Competitive Position?

What is the applicant's relative size and growth in the Industry or the markets, you serve?

What are the types of key collaborators and competitors for the Organisation?

What are the Principal Factors that determine the Applicant's success in relation to its competitors?

How many and what type of competitors do you have?

b) Competitiveness Change

What key changes, if any are affecting your competitive situation, including changes that create opportunities for Innovation and Collaboration, as appropriate?

c) Comparative Data

What key sources of comparative and competitive data are available from within & outside your industry?

What limitations, if any, affect your ability to obtain or use these data?

OP4. Strategic Context

What are the key strategic challenges and advantages in the area of business, operations, human resources and societal responsibilities?

What are the factors critical for the success of the Organisation's strategies?

What are the currently identified key threats and opportunities?

What are the key expectations of the society and their likely impact on the Organisation?

Notes:

Product and Service Delivery mechanisms to your customers might be direct or through Dealers, Distributors, Collaborators, or Channel Partners.

Market segments might be based on Product or Service lines or features, geography, distribution channels, business volume, or other factors that are important to your Organisation to define related market characteristics.

Customer and Stakeholders group and market segment requirements might include on-time delivery, low defect levels, ongoing price reductions, electronic communication, rapid response and after sales service.

Customers are the users and potential users of your products, programs and services.

10

CII EXIM BANK
AWARD FOR
BUSINESS
EXCELLENCE
2 0 2 4

HOW TO APPLY FOR THE AWARD

OP5. Performance Improvement System

What are the key elements of your Performance Improvement System, including your processes for evaluation and improvement of Key organizational projects and processes?

What is the overall approach the Applicant uses to maintain an Organisational focus on performance improvement and to guide systematic evaluation and improvement of key processes?

What is the overall approach to Organisational learning and sharing the knowledge within the Organisation?

4. Elaboration of Direction, Execution and Results

This section comprises the vast majority of the application and will generally have been derived from self-assessment of the Organisation's activities.

This information must be closely aligned with the 7 Award Assessment Criteria.

5. Glossary of Terms

Please give the description of all terms and abbreviations used in the Position Report.

6. Non-Disclosure and Confidentiality

Names of Applicants, comments and scoring information developed during the review of Applications are regarded as proprietary by CII and are kept confidential. Such information is available only to those individuals directly involved in the assessment and administrative process. CII will not release information on successful strategies of Award Recipients and other Applicants without the written approval of the Applicant.

All Assessors are bound by a Code of Conduct. Assessors are required to keep the information gained through the Assessment Process as confidential and not share it with others except other Assessors of their team and Award Secretariat, without the written

approval of the Applicant.

CII will take all reasonable action to ensure that Applications and information therein are treated in strict confidence. However, in no way can CII be held responsible for any loss of confidentiality to a third party. Moreover, CII cannot be held liable for any damage (to goods, or persons, financial or consequential losses) incurred through the breach of confidentiality or otherwise.

HOW TO APPLY FOR THE AWARD

AWARD APPLICATION BROCHURE

7. Fee and Costs

1. The fee for participating in the Award Programme is payable in two instalments – the Application Fee and the Onsite Assessment Fee. See “Fee Structure” below.
- 2a. The Application Fee is payable along with the Application Form.
- 2b. The Onsite Assessment Fee is payable, by the Applicants who qualify for the Onsite Assessment.
3. Travel, Boarding and Lodging and other administrative arrangements to be organized and settled directly by the Applicant.
4. Accommodation to be made in a minimum 4 Star rated Hotel or Equivalent.
5. Travel to be Organized by Air wherever Air connectivity is available.
6. Other incidental expenses such as base location travel, incurred by the Assessors, in connection with the Onsite Assessment, is also to be borne by the Applicant.
7. CII will provide further guidelines in this area, which needs to be adhered to by all applicant to ensure Safety and Comfort of Assessment team
8. Overseas travel to the Assessors will be by Air in Business Class.
9. Overseas Units of Indian Organisations need to make all payments in US\$.
10. Fee payable as per the Annual Sales/Revenue of the Applicant @ existing rates at the time of invoicing.
11. Any Government taxes and levies, will be charged, additionally at actuals, as is prevalent and applicable.
12. All payments are to be made through Online or crossed, at par, cheque or demand draft, favouring “Confederation of Indian Industry” and payable at Bangalore .
13. All payments are **Non-Refundable** and **Non-Adjustable**.

Fee Structure

Annual Sales/Revenue (Rs)	Application Fee	Onsite Assessment Fee
	Domestic Applicants (Rs)	Domestic Applicants (Rs)
Below 250 Cr.	300000 plus 18% GST	300000 plus 18% GST
250-499 Cr.	430000 plus 18% GST	430000 plus 18% GST
500-999 Cr.	535000 plus 18% GST	535000 plus 18% GST
1000-2499 Cr.	585000 plus 18% GST	585000 plus 18% GST
2500-4999 Cr.	610000 plus 18% GST	610000 plus 18% GST
5000-9999 Cr.	630000 plus 18% GST	630000 plus 18% GST
10000 Cr. & Above	675000 plus 18% GST	675000 plus 18% GST

A briefing session to all the award applicants shall be held in May 2024

The Applicant has to bear travel, accommodation and out of pocket expenses.

HOW THE ORGANISATION IS ASSESSED

A team of Assessors, all of whom have undergone training, to ensure a high level of consistency in assessment and scoring, will examine the Position Report.

The Position Report will be assessed and scored on a scale of 0 - 1000 points, based on the EFQM Model. (This document can be obtained from CII).

Essentially the Model requires that:

Outstanding Organisations achieve and sustain outstanding levels of performance that meet or exceed the expectations of all their stakeholders.

The EFQM model is built on Direction & Execution for achieving results.

The Results Criteria are concerned with what the Organisation has achieved and is achieving.

The Direction & Execution Criteria are concerned with how results are being achieved.

For the purpose of meaningful Assessment for the Award, a relative value must be ascribed to the seven criteria within the model. The figures in the model show the maximum number of points that may be given to each of the criterion and the equivalent percentages.

Direction, Execution & Results are valued at 200, 400 & 400 respectively.

EFQM Excellence Model



AWARD ASSESSMENT PROCESS

The Award Assessment process is shown below

Flow Chart: CII EXIM Bank Award for Business Excellence

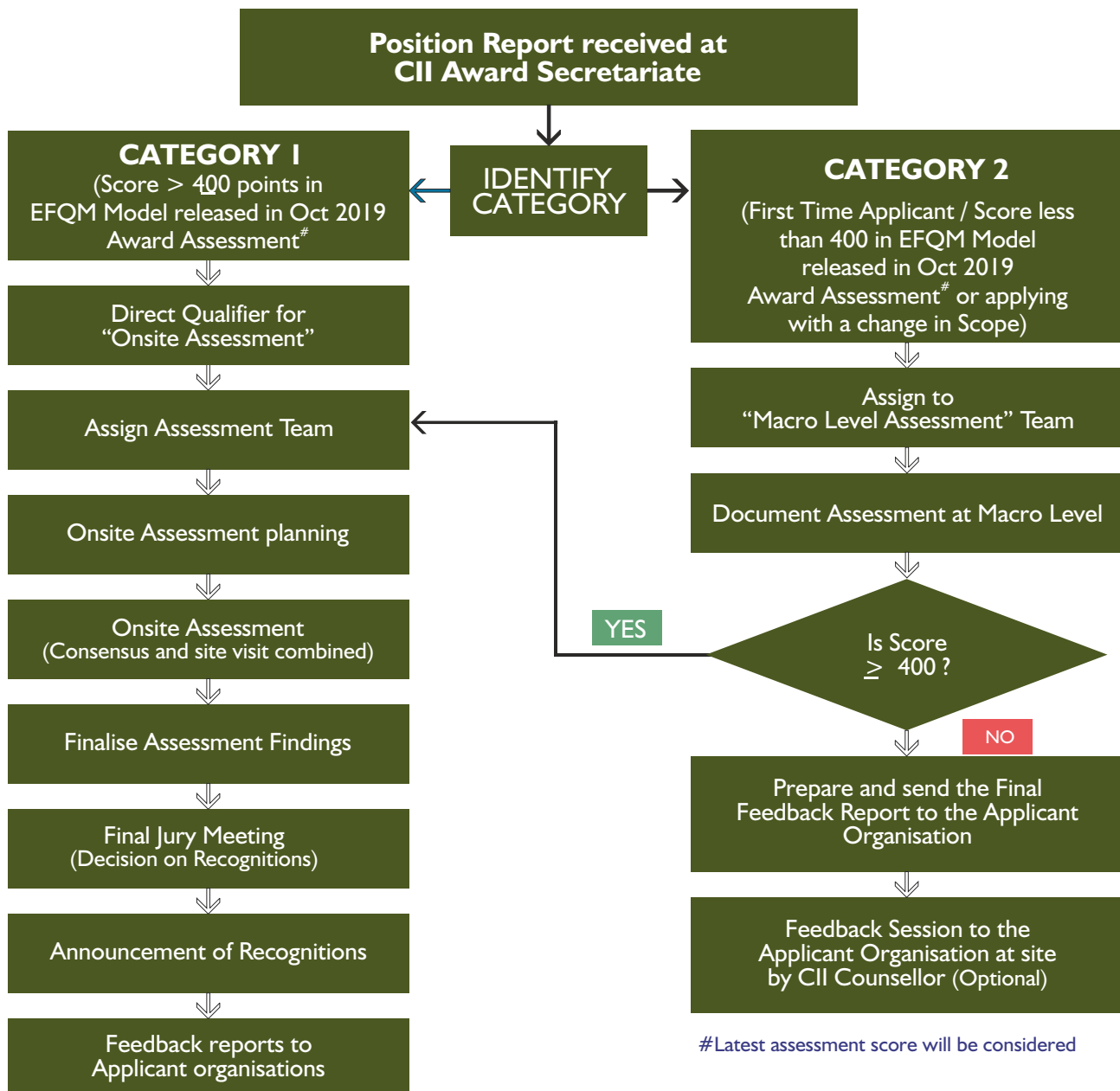

14

CII EXIM BANK
AWARD FOR
BUSINESS
EXCELLENCE
2 0 2 4

AWARD ASSESSMENT PROCESS

Organisations order Application Brochure

Potential Applicants check the eligibility criteria for entry and requirements of the Award Secretariate and send in Application Form with the applicable fee.

Selection of Assessors

Senior Managers from Industry are selected as Assessors. They go through a comprehensive training programme on understanding the award criteria and assessment process.

Applicant Submits Position Report

Applicants send 75 Page Position Report in the prescribed format to CII.

Initial Screening Process for Onsite Assessment

Category 1 : Applicants who have scored 400 or above in EFQM Model Award Assessment[#] will qualify for an Onsite Assessment comprising Consensus and Onsite Assessment.

Category 2: First Time Applicant / Score less than 400 in EFQM Model Award Assessment[#] or applying with a change in Scope

Category 2 applicants will go through a Macro Level Assessment by a team of assessors. Applicants scores 400 or above in Macro Level assessment will qualify for an Onsite Assessment, comprising of Consensus and Onsite Assessment.

Applicants whose score is below 400 in the Macro Level Assessment, will not qualify for an Onsite Assessment and get a Feedback Report at Criteria Level identifying Strengths/Opportunities for Improvement.

Document Assessment and Pre-consensus tele-conferences by Assessment Team

Assessment team is appointed for each Applicant Organisation. Assessors individually list Strengths, Opportunities for Improvement and Scores. Series of Pre-Consensus tele-conferences will be conducted to discuss and reach general consensus on findings.

Onsite Assessment

Assessment team carry out Onsite Assessments, which is a combination of Consensus meeting for ~2 days and Site visit (3-4 days). Post site visit, Assessment team prepare the final report including scoring and sends to CII.

Jury Meeting

Distinguished Individuals from business and academia are appointed as Jurors. Jurors are trained on the Award Model and the Process. Based on the reports from Onsite Assessment Teams, Jurors decide on the winners of the Award and other levels of Recognitions.

Award Presentation

The CII EXIM Bank Award for Business Excellence and other levels of Recognitions are presented to the participating Organisation as per the Jury's decision.

Feedback Report

CII Award Secretariate sends the Feedback Report to all the Applicant Organisations identifying the Strengths & Opportunities for improvement. Score ranges are also given for each criterion. On request, a meeting(virtual mode -tele/video) can be organized with Senior assessor to discuss the Feedback Report.

[#] Latest Score will be considered

RECOGNITIONS

1. Levels of Recognition for Excellence

There are **three levels of recognition**, starting from '**GOLD PLUS**' and going up to the **AWARD**. These levels signify the various milestones, which the Organisations can aim for as they progress on their journey towards Excellence. Therefore, Organisations at different levels of competitiveness can benefit from participating in the Award Process.

The Award Criteria used for assessing is based on the EFQM Model, and hence provides a mechanism to benchmark against world-class Organisations, which are using TQM to drive Excellence.

Awards are presented to Organisations that demonstrate Excellence in the management of Quality as their fundamental process for continuous improvement – the leaders in their respective category.

In addition to the Award, **Jury may recommend organisation(s) for "Jury Commendation for Role Model Organisation"**, if they demonstrate the role model dimensions in one or more areas as evidenced to the Jury

Organisations are commended which have made good progress on their journey towards Excellence, but fall short of the level set for Awards Winners. There are Two Levels of Commendations:

▪

• PLATINUM

• GOLD PLUS

Apart from getting an opportunity for recognition based on maturity level, each Organisation gets an external perspective on their practices and performance. A team of trained assessors with diverse and extensive experience assesses each Applicant Organisation. The assessors spend around 500+ man-hours to identify strengths and opportunities for improvement. A detailed feedback report is sent to all the Applicant Organisations that gives an objective and comprehensive assessment of the current status of the Organisation and forms a sound basis for developing Organisation-wide consensus on strategy for reaching higher levels of competitiveness.

Repeat Applicants from Previous Award Winners shall be considered for 'Role Model Award' if their scores progress to the next 25 point band and also demonstrate 'Role Model' dimensions.

In case of Fatal accidents the organization shall be considered only upto platinum level irrespective of the overall score band.

Organisations winning the Award (600+ scores) consecutively for 3 years shall be conferred 'Sustained Excellence Award'



* Jury Commendation for Role Model Organisation

In addition to the Award, Jury may recommend organisation(s) for "Jury Commendation for Role Model Organisation", if they demonstrate the role model dimensions in one or more areas as evidenced to the Jury

16

CII EXIM BANK
AWARD FOR
BUSINESS
EXCELLENCE
2 0 2 4

WINNERS 2023

CII EXIM Bank Award for Business Excellence 2023 Recognition Winners List

Recognition Level

Award Winner

- High Pressure Boiler Plant (HPBP), Bharat Heavy Electricals Limited
- Alumina Refinery, National Aluminium Company Limited
- Hyderabad Unit, Bharat Electronics Limited

Platinum

- Boiler Auxiliaries Plant (BAP), Bharat Heavy Electricals Limited
- Bosch Automotive Electronics India Pvt. Ltd.
- Jhansi Unit, Bharat Heavy Electricals Limited
- Power Sector-Project Engineering Management, Bharat Heavy Electricals Limited
- Fertilisers Business in Crop Nutrition SBU, Coromandel International Limited
- Electronics Division, Bharat Heavy Electricals Limited
- Panchpatmali Bauxite Mine, National Aluminium Company Limited
- Heavy Electrical Equipment Plant, Bharat Heavy Electricals Limited
- Heavy Electrical Plant, Bharat Heavy Electricals Limited
- Heavy Power Equipment Plant, Bharat Heavy Electricals Limited

Gold Plus

- Jhajjar Power Limited, (An Apraava Energy Group Company)
- IPD & Export AM Business, J.K.Fenner India Limited
- Power Sector -Northern Region, Bharat Heavy Electricals Limited
- Mahyco Private Limited
- Power Sector - Eastern Region, Bharat Heavy Electricals Limited
- Severn Glocon Valves Private Limited
- Smelter Plant, National Aluminium Company Limited

Gold Plus - SMB Category

- Soil Institute of Management (Unit of Grow Talent Co. Ltd.)

WINNERS 2022

CII EXIM Bank Award for Business Excellence 2022 Recognition Winners List

Recognition Level

Award Winner + Role Model Organization

- Ghaziabad Unit, Bharat Electronics Ltd.

Award Winner

- Godrej Construction

Platinum

- Alumina Refinery
- National Aluminium Co. Ltd.
- Heavy Electrical Bhopal Unit BHEL
- Heavy Power Equipment Plant Hyderabad Unit, BHEL
- Heavy Electrical Equipment Plant Haridwar Unit, BHEL
- High Pressure Boiler Plant Tiruchirappalli Unit BHEL
- Hindustan Zinc Limited
- SEG Automotive India Private Limited

Gold Plus

- Project Engineering Management Noida Unit, BHEL
- Power Sector - Northern Region Noida Unit, BHEL
- Boiler Auxiliaries Plant Ranipet Unit, BHEL
- Electronic Division, Bangalore Unit, BHEL
- Captive Power Plant, National Aluminium Co. Ltd.
- Engineering Business, Pashamylaram Plant, J.K. Fenner (India) Limited
- Panchpatmali Bauxite Mine, National Aluminium Co. Ltd.

18

CII EXIM BANK
AWARD FOR
BUSINESS
EXCELLENCE
2 0 2 4

WINNERS 2021

CII EXIM Bank Award for Business Excellence- 2021 Recognition Winners List

Recognition Level

Award Winner

- Godrej Precision Engineering, Godrej and Boyce Mfg. Co. Ltd
- Godrej Construction, Godrej & Boyce Mfg. Co. Ltd.
- Dolvi Works, JSW Steel Limited
- Kirloskar Ferrous Industries Limited

Platinum

- Chennai Unit, Bharat Electronics Limited
- Hyderabad Unit, Bharat Electronics Limited
- Heavy Electrical Equipment Plant, Haridwar Unit, BHEL
- Heavy Electrical Plant, Bhopal Unit, BHEL
- ALUMINA REFINERY, National Aluminium Co. Ltd.

Gold Plus

- Heavy Power Equipment Plant, Hyderabad Unit, BHEL
- High Pressure Boiler Plant, Tiruchirappalli Unit, BHEL
- Panchpatmali Bauxite Mine, National Aluminium Co. Ltd.
- RSJ Inspection Service Limited (SMB)

WINNERS 2020

CII EXIM Bank Award for Business Excellence- 2020 Recognition Winners List

Recognition Level

Award Winner

- Godrej Precision Engineering , Godrej & Boyce Mfg. Co. Ltd., Mumbai

Jury Commendation for CONSISTENT PROGRESSIVE PERFORMANCE

- Kirloskar Ferrous Industries Ltd, Koppal

Platinum

- Heavy Electrical Equipment Plant, Haridwar, Bharat Heavy Electricals Ltd
- HERE Technologies, Mumbai
- Kirloskar Ferrous Industries Ltd, Koppal
- Alumina Refinery, Damanjodi, National Aluminium Company Ltd

Gold Plus

- Panchpatmali Bauxite Mine, National Aluminium Company Ltd
- Smelter Plant Angul, National Aluminium Company Ltd
- RSJ Inspection Service Limited (SMB)

20

CII EXIM BANK
AWARD FOR
BUSINESS
EXCELLENCE
2 0 2 4

WINNERS 2019

CII-EXIM Bank Award for Business Excellence- 2019 Recognition Winners List

Recognition Level

Award Winner + Role Model Organization

- Appliances Division, Godrej & Boyce Mfg. Co. Ltd.

Award Winner

- Kirloskar Oil Engines Limited

Platinum

- Ace Designers Limited
- Alumina Refinery, National Aluminium Company Limited
- CESC Limited
- Dolvi Works, JSW Steel Limited
- Fertilisers SBU, Coromandel International Limited
- Ghaziabad Unit, Bharat Electronics Limited
- Hyderabad Unit, Bharat Electronics Limited
- Godrej Precision Engineering, Godrej and Boyce Mfg. Co. Ltd
- Kirloskar Ferrous Industries Limited

Gold Plus

- Mathura Refinery, Indian Oil Corporation Limited
- Patancheru Plant, J K Fenner (India) Limited
- Rubber Processing Machinery Business Unit, Larsen & Toubro Limited

WINNERS 2018

CII EXIM Bank Award for Business Excellence- 2018 Recognition Winners List

Recognition Level

Award Winner + Role Model Organization

- Bengaluru Unit, Bharat Electronics Limited

Award Winner

- Appliances Division, Godrej & Boyce Mfg. Co. Ltd.

Platinum

- Ace Designers Ltd
- Ghaziabad Unit, Bharat Electronics Limited
- Chennai Unit, Bharat Electronics Limited
- Machilipatnam Unit, Bharat Electronics Limited
- Godrej Precision Engineering Division, Godrej & Boyce Mfg. Co. Ltd
- Dolvi Works, JSW Steel Ltd.

Gold Plus

- Air-Conditioning & Refrigeration Service Group, Blue Star Limited
- Madhurai Plant, J. K. Fenner (India) Limited
- Alumina Refinery, National Aluminium Company Limited, Damanjodi
- Kalyani Plant, Phoenix Conveyor Belt India (P) Limited
- Optical Fiber Unit, Sterlite Technologies Ltd, Aurangabad

22

CII EXIM BANK
AWARD FOR
BUSINESS
EXCELLENCE
2 0 2 4

FURTHER SUPPORT

Training Services

- One day Appreciation programme on Business Excellence
- Three Day Assessor Training on Business Excellence
- Three Day Practitioners' Workshop on Business Excellence*
- Customized Two day Excellence Programme on various Functions. (e.g., Mfg, Sales & Mktg etc)

All programmes are offered in open / in- house format. Prices would vary depending on the programme.

* Practitioners' programme is directed at functional managers for understanding how to achieve Excellence in their functions and align with other functions and Organizational strategy.

Counselling Services

Counselling is provided for Implementation of Business Excellence based on a customized roadmap developed by the CII Counsellors following an assessment of the Organization and considering the priorities and expectations of the Organization.

Fee would be charged on a man day basis and other expenses on actual.

OEM Clusters

"Clusters for Business Excellence" with a set syllabus, timelines and modular content is available for OEM Supplier clusters for enabling OEMs to help Key suppliers put practices and processes in place.

Award/Prize Winning Position Reports:

(Rs 5000/- per copy, inclusive of GST and courier charges)

(Award Winner of 2023) shall be available by end Feb 2024

- Bharat Electronics Limited
- Godrej Precision Engineering, Godrej & Boyce Mfg. Co. Ltd
Godrej Construction, Godrej & Boyce Mfg. Co. Ltd.
Dolvi Works, JSW Steel Limited
Kirloskar Ferrous Industries Limited
- Godrej Precision Engineering, Godrej & Boyce Mfg Co Ltd
(Award Winner of 2020) Appliances Division, Godrej & Boyce Mfg Co Ltd.
(Award Winner + Role Model Organization of 2019)
- Kirloskar Oil Engines Ltd
(Award Winner of 2019)
- Bengaluru Unit, Bharat Electronics Limited.
(Award + Role Model Organization of 2018)
- Appliances Division, Godrej & Boyce Mfg Co Ltd.
(Award Winner of 2018)
- Godrej Interio, Godrej & Boyce Mfg Co Ltd.
(Award Winner of 2017)
- Godrej Appliance, Godrej & Boyce Mfg Co Ltd.
(Prize Winner of 2017)
- Raychem RPG (P) Ltd.
(Prize Winner of 2017)
- Bhilai Steel Plant, SAIL
(Prize Winner of 2016)
- National Stock Exchange of India Ltd.
(Prize Winner of 2016)
- Bosch Limited, Diesel Systems business – Jaipur
(Prize Winner of 2016)
- Rallis India Ltd.
(Prize Winner of 2015)

For more details, please contact:

Sudha S
Deputy Director

Award Secretariat
Confederation of Indian Industry
CII Institute of Quality
Near Bharat Nagara, 2nd Stage,
Viswaneedham Post, Bangalore - 560
091

Tel: 080 - 2328 6085 / 9391 / 7690
Fax: 080 - 2328 9388 / 2358 0314
Mobile: 98864 93998
email: sudha.s@cii.in
Website: www.cii-iq.in



Confederation of Indian Industry

CII EXIM Bank Award for Business Excellence – Year 2024



1.0 *Name of Applicant Organisation
(as it should appear in the Certificate)

.....

1.1 Address

.....

.....

Pin Code: GST No:

.....

2.0 *Name of the Contact Person

.....

2.1 Designation

.....

2.2 Telephone *Mobile

.....

2.3 Fax

.....

2.4 *Email

.....

2.5 Contact Address (if different from above)

.....

.....

.....

3.0 *Name of the Highest Ranking Official

.....

3.1 *Designation

.....

3.2 Telephone *Mobile

.....

3.3 Fax

.....

3.4 *Email

.....

4.0 *Products and Services offered

.....

.....

4.1 *Number of Locations / Sites

.....

4.2 *Total Number of Employees

.....

4.3 *Annual Sales / Revenue (in Rs. Cr.)

.....

4.4 *Type of Organisation (Please tick in the appropriate box)

a Large Business Organisation b Operating Units

4.5 *Are you a member of CII: Yes No

4.6 *Scope of Assessment (Geography / Businesses etc.)

.....

.....

4.7 *Applicant Category (Please tick in the appropriate box)

Category 1 Category 2

(Score ≥ 400 points in
EFQM 2013 Model Assessment[#])

(First Time Applicant / Score less than 400 in EFQM 2013
Model Assessment[#] or applying with a change in Scope)

[#] Latest Score will be considered
* Mandatory (to be filled)

Note: (Refer Page 6 for Eligibility Criteria)

Give the following information if Applicant is not a "Whole Organisation":

- 5.0 Name of Parent Organisation
.....
- 5.1 Address
.....
- 5.2 Telephone
.....
- 5.3 Fax
.....
- 5.4 Name of the Highest Ranking Official of Parent Organisation
.....
- 5.5 Designation
.....
- 5.6 Total Number of Employees
.....
- 5.7 Annual Sales / Revenue (in Rs. Cr.)
.....
- 5.8 Describe the relationship between the Applicant and the Parent Organisation and provide an Organisation Chart showing the relationship
.....
.....

I agree, on behalf of my Organisation, to abide by the rules of the CII EXIM Bank Award for Business Excellence Programme and accept that the decisions of the CII are final. I confirm that my Organisation is eligible to take part in this Programme and that all information in this Application Form is and accompanying Position Report are correct. I accept the Time Table, the Non-Disclosure, Confidentiality Clause and fee & cost structure. (Refer the below notes and page 10 and page 11 of the award application brochure for more details)

Please find below the application fee payment details:

Payment of Rs..... through online..... Dated.....

Date _____

(Signature of Highest Ranking Official & Company Seal)

Time Table for the Year 2024

30 April 2024

Final Date for Receipt of Application Form by CII Award Secretariat.

15 July 2024

Final Date for Receipt of the Position Report by CII Award Secretariat.

15 July - 15 October 2024

Onsite Assessment, where applicable.

Notes

- Attach this form duly filled and signed with the Position Report also.
- The photocopy of this Application Form may be used wherever necessary.
- All Assessors are bound by a Code of Conduct and are required to sign a Non Disclosure Agreement with CII. There will not be any separate NDA with Organization by Assessors or by CII and no such request can be processed.
- Team formation: Team may consist of working professionals, Freelancers & Consultants and the final composition of the the team is under discretion of the Award Secretariat and no specific request can be accepted in this regard.
- Boarding, Lodging & Travel Expenses to be organized and settled by the applicant for the on-site visit. (Refer Award Application brochure - page 10 and 11 for further details on Non Disclosure Clause, Fee and Cost)

Address for correspondence:

Sudha S
Deputy Director
Award Secretariat
Confederation of Indian Industry
CII Institute of Quality
Near Bharat Nagara, 2nd Stage, Viswaneedham Post, Bangalore - 560 091

Tel: 080 - 2328 6085 / 9391 / 7690
Fax: 080 - 2328 9388 / 2358 0314
Mobile: 98864 93998
email: sudha.s@cii.in
Website: www.cii-iq.in

25

AWARD
APPLICATION
BROCHURE

ACKNOWLEDGE- MENT

Confederation of Indian Industry acknowledges the support and co-operation extended by EXIM Bank of India and EFQM for institutionalising CII Award for Business Excellence.

The Award Secretariate thankfully acknowledges the support extended by the Jurors, Process Consultants, Senior Assessors, Assessors and Organisations supporting the Award Administration and their contribution in propagating Excellence in India Inc.

26

CII EXIM BANK
AWARD FOR
BUSINESS
EXCELLENCE
2 0 2 4

WINNERS OF OTHER LEVELS OF RECOGNITIONS

OVER THE YEARS...

- Ace Designers Limited
- Air-Conditioning & Refrigeration Service Division, Blue Star Ltd
- ASE Structure Design Pvt Ltd.
- Angelique International Limited
- Apollo Hospitals, Chennai
- AVB Group of Companies
- B M Birla Heart Research Centre
- Bharat Electronics Limited
- Bharat Heavy Electronics Limited
- Brigade Group
- CESC Limited
- Crompton Greaves Limited
- Fortis Hospital
- Godrej Group of Companies
- Grundfos Pumps India Private Limited
- Hindalco Industries Limited
- Humming Bird Digital Private Limited
- Imerys Steelcasting India Pvt Ltd
- Indelox Services Private Limited
- Infotech Enterprises Limited
- Inteliment Technologies (India) Private Limited
- J.K. Fenner (India) Limited
- JCB India Limited
- JSW Steel Coated Products Ltd
- JSW Steel Limited
- Kalpataru Limited
- Kirloskar Group of Companies
- L&T Group of Companies
- Maruti Suzuki India Limited
- Moolchand Medcity
- Murugappa Group of Companies
- NTPC Limited
- Overseas Infrastructure Alliance (India) Pvt Ltd.
- PSG Institute of Management
- Pushpak Products India Pvt Limited
- Rashtriya Ispat Nigam Limited
- Raychem RPG (P) Ltd.
- Robert Bosch Eng. & Business Solutions Pvt Ltd.
- Satish Injecto-Plast Private Limited
- Shreekrupa Enterprises
- SSA Business Solutions Private Limited
- Steel Authority of India Limited
- Subros Limited
- Susira Industries Limited
- T V Super Filter Industries
- TATA Group of Companies
- Tractors and Farm Equipment Limited (TAFE)
- Thinksoft Global Services Limited
- Triveni Engineering & Industries Limited
- Triveni Turbine Limited
- TTK Healthcare TPA Private Limited
- Weir Minerals India Private Limited
- Wendt (India) Limited
- YES Bank
- SEG Automotive India Pvt Ltd
- Hindustan Zinc Ltd
- and many more....

Business Excellence

Maturity Assessment Programme

Seed...

Nurture...

Harvest...

Recognize

Internalize

Initiate



Pursue The Path of....

BUSINESS EXCELLENCE

... Profit From It

Initiating Excellence

Organizations initiating Business Excellence through a baseline assessment



Assessments can be scheduled on mutually convenient dates throughout the year

Process steps

A 2 day dip-stick assessment by two Assessors interacting with key personnel of the organization to understand their process and performance maturity.

This would involve a walkthrough of Business, Support and Management processes with the associated results based on excellence framework requirements. This category of assessment does not require any formal documentation.

Output

- Baseline score of organizational maturity on a 1000 point scale
- Prioritized action plan and roadmap with milestones

Support

CII will facilitate Organizations to progress on the suggested roadmap through hand holding visits, customized training through appropriate frameworks.

On completion of this phase, Organizations can progress to the Internalizing Phase. Initiators would generally take 12 - 15 months to move to the next phase.

**Recognized for Adoption of Excellence
At CII Flagship Event 2024**

Internalizing Excellence

For Organizations on the journey of Excellence on any Framework

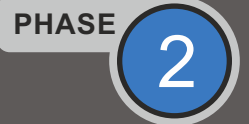

Assessments can be scheduled on mutually convenient dates throughout the year

Process steps

Assessors with rich industry experience will interact with all functions of the organization considering the Business Strategy and Operating Context, to identify key strengths and opportunities for improvement. There are two categories to opt as given below.

CATEGORY 1	CATEGORY 2	TURNOVER
Document less Assessment	Minimal documentation 20 - 30 page Format	<100 Crores SMB Organizations
2 - 3 day Assessment*	3 - 4 day Assessment*	
2 Assessors	2 Assessors	>100 Crores Large Organizations
Recognition Silver: Score of 300 & above	Recognition Silver: Scores between 300- 399 Gold: Scores 400 & above	

NOTE:

These category of Assessments do not fall under the Award Scheme. However, Organizations will be felicitated based on the score obtained under the relevant category. Companies running their own internal assessments can also opt for recognitions when the assessments are administered by the CII IQ team. Assessment can be based on any Excellence framework.

*Assessment Days will vary depending on the Business Size and complexity

Output

- Action oriented Management Report
- Way forward with Milestones
- Criteria wise report of strengths and key opportunities for improvement aligned to Excellence Framework requirements

**Silver / Gold Category Recognitions
At CII Flagship Event 2024**





ABOUT CII INSTITUTE OF QUALITY

CII Institute of Quality is the leading authority in Quality Enhancement among organization and industries. Over the past century, CII has provided Indian Industries with the support, systems and tools to make a mark in the competitive world. It is realized that the best way to enhance an organizations competitiveness is through the quality route.

What started as the Total Quality Management Division (TQMD) in the mid-eighties has now evolved as CII Institute of Quality. As a champion of the Quality movement, CII-IQ is powered by the responsibility of enriching the lives of its members, improving their workplaces and making the world a better place by applying quality tools, techniques and systems. CII-IQ provides the best of its kind training and consulting services to organizations to help improve their performance and set a standard of excellence.

CII IQ has tied up with several international organizations to bring their best practices in India. It has helped several organizations improve their Total Quality Management Systems besides helping them win recognitions.

Contact

Sudha S
Deputy Director
sudha.s@cii.in
+91 9886493998

N Deep
Director
n.deep@cii.in
+91 9845353135

P M Krishnan
Principal Counsellor
Business Excellence
krishnan.pm@cii.in
+91 9632661888

M S Srinivasan
Principal Consultant
Business Excellence
ms.srinivasan@cii.in
+91 9620226100

CII Institute of Quality

The K N Shenoy Centre

Near Bharat Nagara II Stage, Viswaneedam Post,
Magadi Road, Bangalore 560 091, Karnataka, India
E: cii-iq@cii.in W: www.cii-iq.in/ www.ciibizex.in



www.ciibizex.in



Confederation of Indian Industry

Near Bharat Nagara, 2nd Stage,
Magadi Main Road, Vishwaneedam Post,
Bangalore 560 091

Ph : 080 - 2328 7690 / 9391 / 6085

Fax : 080 - 2328 9388, 2358 0314

Website: www.cii-iq.in

CII INSTITUTE OF QUALITY

